



## Whitehall Compact Surgical Scrub Sink One Station

Model 4111

Please visit [www.whitehallmfg.com](http://www.whitehallmfg.com)  
for most current specifications.



4111

Fixture May Show Some Available Options

**Surgical Scrub Sink** is designed for use in health care institutions providing surgeons with a convenient sink for pre-op scrub up.

**Fixture** is fabricated from heavy gage, type 304 stainless steel and is seamless welded construction with a satin finish. The cabinet interior is sound-deadened with a fire-resistant material. The unit is designed to be installed on the wall using a mounting carrier.

**Scrub Sink** is provided with a front panel which is easily removed for access to the water control valves, waste connections, stops and strainers. Scrub sink has a sloping bottom surface to minimize splashing and a 1-1/2" OD tailpiece with a 3" flat strainer drain.

**Backsplash** has a gooseneck spout assembly with sprayhead that can be removed for sterilization.

**Hands Free Operation** includes infrared sensor located on back panel.

**T/P Temperature/Pressure Balancing Mixing Valve** is located behind the front panel and maintains a constant water temperature with a flow control of 2.5 GPM. This easily adjustable, anti-scald valve will automatically shut off if the hot or cold water supply fails.

**Solenoid Valve** is a slow closing, anti-water hammer type.

### GUIDE SPECIFICATION

Provide Whitehall Compact Surgical Scrub Sink (specify model number and options). Fixture shall be fabricated from heavy gage, type 304 stainless steel, with seamless welded construction with a satin finish. Cabinet interior shall have a sound deadening, fire-resistant material. Cabinet shall also have removable access panel to allow access to water control valves, waste connections, stops and strainers. Sink shall have a sloping bottom to minimize splashing, and a 3" flat strainer drain. Gooseneck shall have a removable sprayhead. Fixture shall have a T/P temperature/pressure balancing mixing valve with slow closing, anti-water hammer solenoid valve, infrared sensor and transformer. Transformer must be wired to a GFI protected circuit. Manufacturer shall provide necessary installation instructions.

Please visit [www.whitehallmfg.com](http://www.whitehallmfg.com)  
for most current specifications.



Member of  
U.S. Green  
Building  
Council



Recyclable  
Product



**BASE MODEL NUMBER**

- 4111 Compact Surgical Scrub Sink (1 Station)

**MOUNTING**

- MC Mounting Carrier

**Product Options**

- EYW Eyewash
- LFN Laminar Flow Nozzle 1.5 GPM
- SWV Swivel Nozzle on Gooseneck

**Accessories**

An appropriate Chronomite Instantaneous Tankless Water Heater may be purchased separately to ship with your scrub sink. Contact your sales rep for details or visit [www.chronomite.com](http://www.chronomite.com)

Please visit [www.whitehallmfg.com](http://www.whitehallmfg.com) for most current specifications.

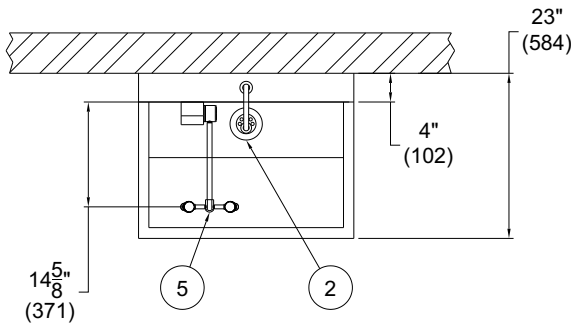

**NOTES:**

1. Gooseneck Spout Assembly.
2. Flat Strainer Drain.
3. Removable Access Panel.
4. Infrared Sensor.
5. Optional -EYW Eyewash

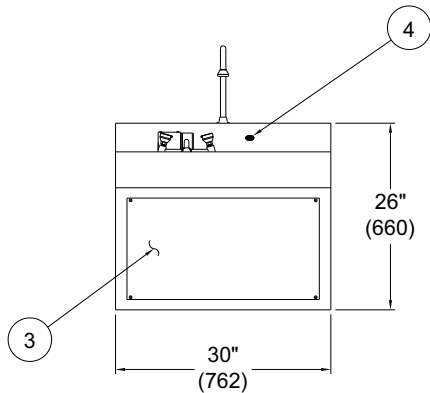

MODEL# 4111-MC-EYW-LFN

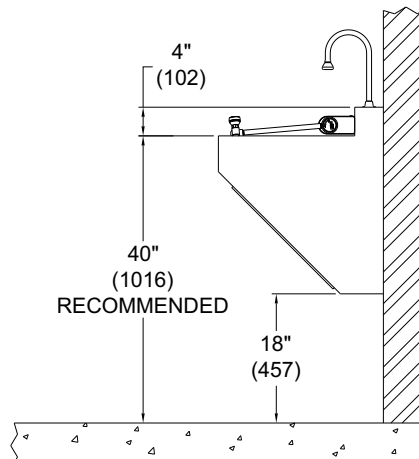

All dimensions are nominal and subject to manufacturer's change without notice. Whitehall assumes no responsibility for use of void or suspended data © Whitehall Manufacturing, Member of Morris Group International. Please visit [www.whitehallmfg.com](http://www.whitehallmfg.com) for most current specifications.

**SELECTION SUMMARY & APPROVAL FOR MANUFACTURING**

Model Number & Options \_\_\_\_\_ Quantity \_\_\_\_\_  
 Company \_\_\_\_\_ Date \_\_\_\_\_  
 Contact \_\_\_\_\_ Title \_\_\_\_\_  
 Approval for Manufacturing/Signature \_\_\_\_\_