

**A171.8 Series**  
**Barrier Free, Wall Mounted Water Cooler**  
**With -BF2 Sensor Operated Bottle Filler**

SUGGESTED SPECIFICATIONS

Model A171108F-BF2 is a self-contained, pressurized water cooler that delivers a minimum of 8.0 GPH (30.3 LPH) of water at 50°F (10°C) cooled from 80°F (26.7°C) inlet water and 90°F (32.2°C) ambient. Unit shall be activated from a pushbutton in the front, using less than 5 pounds of force. Bubbler shall deliver a 0.3 GPM flow, have an anti-microbial flexible guard with an integrally designed non-squirt feature and operate on a water pressure range of 20-105 psig. Basin shall be constructed from 304 stainless steel and have an integral drain. Unit includes model BF2 sensor operated bottle filler. Water cooler and bottle filler cabinets shall be either galvanized steel with granite powder coat or stainless steel. Cooling system shall use R-134a refrigerant and be capillary tube regulated. An adjustable thermostat with an off position shall regulate the refrigeration system. Unit shall be listed by Underwriters Laboratories for both the US and Canada and is compliant to the Air Conditioning and Refrigeration Institute Standard 1010. Unit is certified to ANSI A117.1, ANSI/NSF 61.9 and Public Law 111-380. Fixture meets ADA, ADA Standing Person, and ADA Child requirements when mounted appropriately.

**Standard Model:**  
A171108F-BF2

**Stainless Steel Model:**  
A171408F-BF2S



Model A171108F-BF2 Shown  
\*\* U.S. DESIGN PATENT PENDING



STANDARD FEATURES

- Child or Adult ADA Compliant (when properly installed)
- Granite powder coated apron and one-piece bottom wrapper
- Flexible, Low Flow, anti-rotation, non-squirt bubbler
- 100 mesh inlet strainer
- Vandal resistant screws
- Individual hanging brackets provided
- Auto-stop allows cartridge and strainer service without shutting off water supply
- Laminar Flow Water Supply
- 1 G.P.M. Fill Rate
- 100% Lead & Brass Free



Member of  
U.S. Green  
Building  
Council



Recyclable  
Product



Water  
Conserving  
Product

CONFIGURING SPECIFIC MODEL NO. & OPTIONS

**A171108F-BF2**

**Material/Finish**  
1 Granite (Std)  
4 Stainless Steel

**Bubblers**  
F Flexible (Std)  
S Lead-Free  
Stainless Steel

**Bottle Filler**  
BF2 Granite (Std)  
BF2S Stainless Steel

Custom color finishes  
available upon request

**WATER COOLER OPTIONS**  
(May add additional costs)

- BP8 Back panel, stainless steel
- CSC2 Concealed support carrier
- GF1 Glass filler with lever handle
- WF1 1500 gallon capacity, NSF 42+53, 1 micron lead reduction filter
- 220V 220 volt / 50 Hz compressor (€€)

**BOTTLE FILLER OPTIONS**  
(May add additional costs)

- BAT Battery Operated (N/A With Bottle Counter)
- BCD Bottle Counter Display

Acorn Engineering Company™ assumes no responsibility for use of void or superseded data.  
© Copyright Acorn Engineering, City of Industry, CA Member of Morris Group International.  
Please visit [www.maxsupply.com](http://www.maxsupply.com) for most current specifications.

**A171.8-BF2**

Date: 08/11/14

COMPLIES WITH STANDARDS



ANSI / NSF 61.9



Federal Public Law 111-380 (No Lead) Test rating conditions are compliant with ARI 1010.



**MaxSupply**

Fax: 1-888-828-6021  
Website: [www.MaxSupply.com](http://www.MaxSupply.com)  
Email: [sales@maxsupply.com](mailto:sales@maxsupply.com)

# TECHNICAL DIMENSIONS

All dimensions are subject to manufacturer's tolerance of plus or minus 1/2" nominal and subject to change without notice. Acorn Engineering Company™ assumes no responsibility for use of void or superseded data. © Acorn Engineering Company®, City of Industry, CA, Member of Morris Group International™. Please visit [www.acorndrinkingfountains.com](http://www.acorndrinkingfountains.com) for most current specifications.

**Standard Model:**  
A171108F-BF2

**Stainless Steel Model:**  
A171408F-BF2S

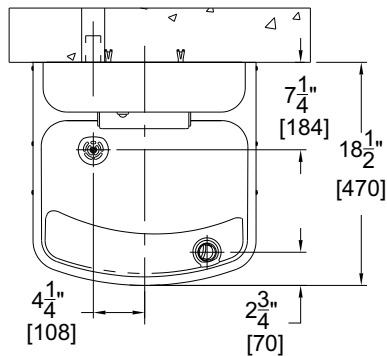

**GENERAL NOTES:**

1. ALL DIMENSIONS ARE IN INCHES [MM]
- \*2. DIMENSIONS SHOWN ARE FOR RECOMMENDED ADULT HEIGHT. ADJUST VERTICAL DIMENSIONS AS NECESSARY TO COMPLY WITH FEDERAL, STATE & LOCAL CODES.
3. ANGLE STOP VALVE & TRAP NOT SUPPLIED.
4. IMPORTANT: FOUNTAINS MUST BE ATTACHED TO WALL WITH APPROPRIATE ANCHORING HARDWARE.

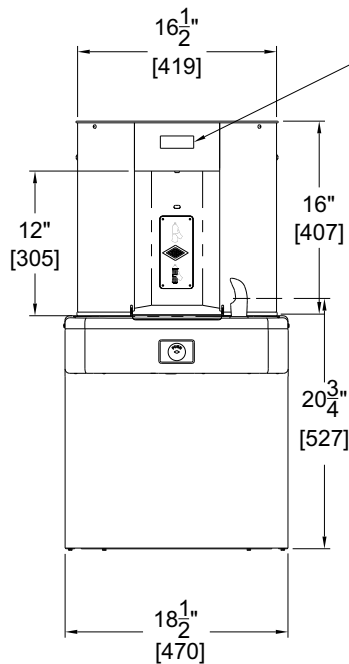

BOTTLE COUNTER AND  
FILTER REPLACEMENT DISPLAY

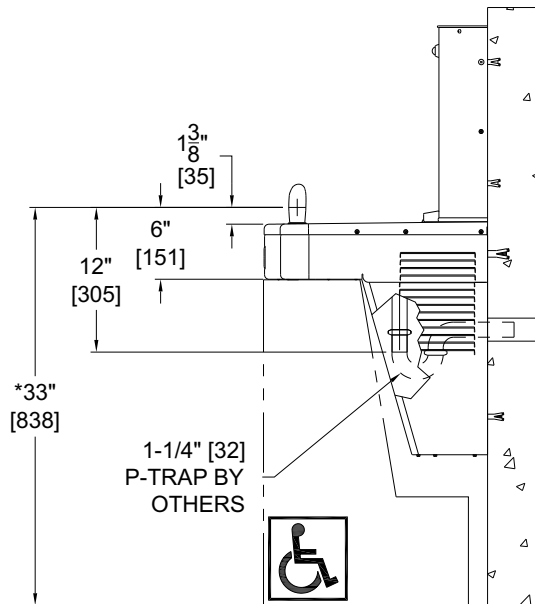

SIDE VIEW

**A171.8-BF2** Date: 08/11/14

Acorn Engineering Company™ warrants that its products are free from defects in material or workmanship under normal use and service for a period of one year from date of shipment. Acorn's™ liability under this warranty shall be discharged solely by replacement or repair of defective material, provided Acorn™ is notified in writing within one year from date of shipment, F.O.B. Industry, California.

SELECTION SUMMARY & APPROVAL FOR MANUFACTURING

Company \_\_\_\_\_

Model Number & Options \_\_\_\_\_ Quantity \_\_\_\_\_

Contact \_\_\_\_\_ Title \_\_\_\_\_

Signature (Approval for Manufacturing) \_\_\_\_\_

Date \_\_\_\_\_



Fax: 1-888-828-6021  
Website: [www.MaxSupply.com](http://www.MaxSupply.com)  
Email: [sales@maxsupply.com](mailto:sales@maxsupply.com)