

Location:



P6290

12" Wide, Stainless Steel Frame and Grate System

SPECIFICATION:

MIFAB® Series P6290, 12" wide, Load Class "A" Light duty slotted trench drain ADA compliant grate constructed of Type 304 stainless steel with 10 gauge stainless steel angle frame and anchor tabs. Free area of 23.00 square inches per 1' section. Also available with B, C, and D load rated stainless steel grates and optional anchor flange (Suffix -FL).

FUNCTION:

Used in laboratory, industrial, commercial, kitchen and other hygienic and/or corrosive areas. Type 304 stainless steel construction provides for ease of cleaning, maintenance and sanitary installation. All grate openings are polished to a smooth finish.

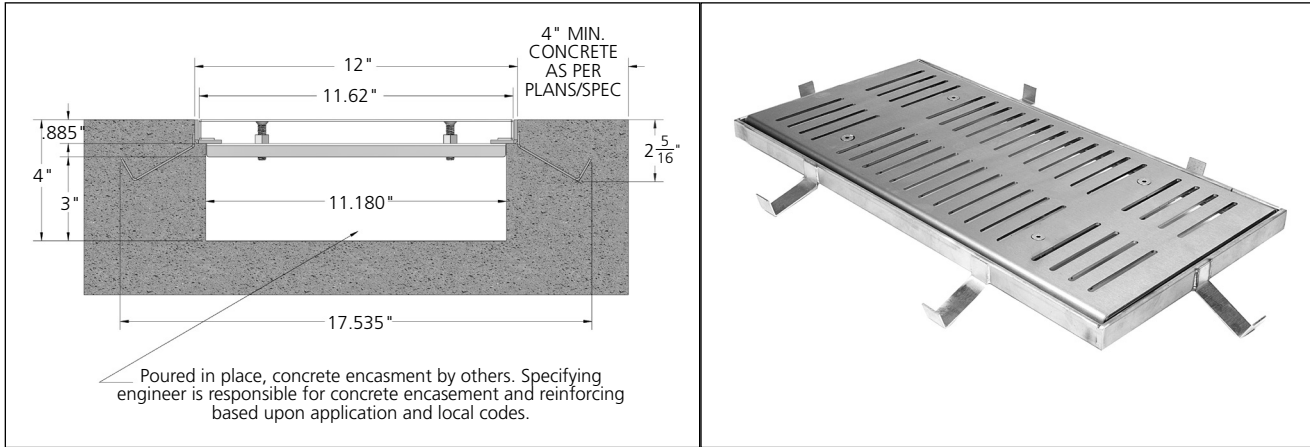

See pages 15 and 16 for the optional grate designs.

MODEL NUMBER	DESCRIPTION
P6290	12" wide, Type 304 Stainless Steel Frame and Grate System (Load Class "A", "Light Duty" ADA compliant grates)
P6290-29	12" wide, Type 316 Stainless Steel Frame and Grate System (Load Class "A", "Light Duty" ADA compliant grates)

SUFFIX	OPTIONAL VARIATIONS	DESCRIPTION
	-LCB	Load Class "B", Medium Duty Grate (2,000 - 4,999 lbs.)
	-LCC	Load Class "C", Heavy Duty Grate (5,000 - 7,499 lbs.)
	-LCD	Load Class "D", Extra Heavy Duty Grate (7,500 - 10,000 lbs.)
	-LS	Longitudinal Slotted Grate (ADA Compliant)
	-NS	Slip Resistant Grate (Non slip grit finish)
	-PG	Perforated Grate (1/4" diameter holes)
	-PHP	Perforated "Heel Proof Grate" (less than 1/4" diameter perforations)
	-SHP	Slotted "Heel Proof" Grate (less than 1/4" wide slots)
	-5	Sediment Bucket
	-6	Vandal Resistant Grate
	-90	90 Degree Section

Job Name: <input type="text"/>	Page No: <input type="text"/>
Section No: <input type="text"/>	Contract: <input type="text"/>
Schedule No: <input type="text"/>	Purchase Order No: <input type="text"/>