

PARAFFIN THERAPY

Whitehall Paratherapy

Durable **stainless steel construction**



Operating **indicator light**

Holds **6 lbs** (PT-6-S) or **18 lbs** (PT-18-S) of paraffin wax

Dickson™ Paraffin

High-end **solid hard wood** accent is durable and stays cool to the touch



Largest paraffin bath available in the industry holds up to **50 lbs** of paraffin wax

Rolling stand included

Holds **6 lbs** of paraffin wax

Thermometer provides safety for both the patient and therapist



Switch manually turns on/off sanitizing cycle

High-heat light indicates the unit is in sanitizing mode

Timer allows for unattended sanitizing

PARAFFIN THERAPY

*Dickson*TM Paraffin Tanks

Dickson paraffin baths have evolved since 1924 to become the finest name in the application of paraffin and an essential part of Whitehall's® therapy product line. These top-of-the-line models are luxuriously finished with solid hardwood moldings that are contoured to provide a comfortable, cool rest for an arm or leg.

Dickson models are also designed to provide luxuries to the caregiver. Each unit has a high-heat sanitizing circuit. A timer is available on some units and when activated, it provides an unattended hour of high heat that sanitizes the paraffin. This is especially convenient, as paraffin can be timed at the end of the day to sanitize while not in use, saving time and maintaining a sanitary environment.



The **PB-105** is the largest clinical paraffin unit in the industry. It is provided with a two-piece cover that enables a user to expose either one or both halves at a time, while the **PB-104** has a single lid and is half the size of the **PB-105**.



Model PB-105

55lb capacity stainless tank
with mobile stand



Model PB-104

22lb capacity stainless tank
with mobile stand

Also included with both models is a bi-metal thermometer that is recessed in the hardwood molding for added safety. Both have a timed high-heat circuit, making them ideal for clinics, nursing homes, and doctor's offices where sanitation is important.



PARAFFIN THERAPY

Dickson™

Paraffin Tanks continued

The small model **PB-107** utilizes a timer-controlled high heat sanitizing circuit. The **PB-101** has a three-way switch for activation of the high heat sanitizing circuit and must be manually switched back to maintain treatment temperature. These space-saving and economical Dickson paraffin baths are normally placed on a counter or on the floor. An optional stand is available.



Model PB-107

6lb capacity paraffin tank on PB-222 stand



Model PB-101

6lb capacity paraffin tank on PB-222 stand

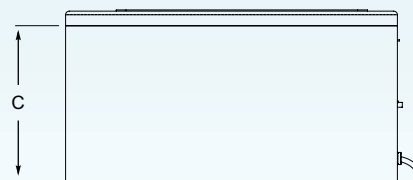
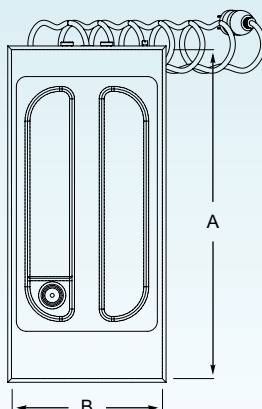

Models

model	PB-101	PB-107	PB-104	PB-105
A - interior length - in (mm)	12 (200)	12 (200)	14 (360)	25 (640)
B - interior width - in (mm)	6 (150)	6 (150)	7 (180)	11-1/2 (290)
C - interior height - in (mm)	6 (150)	6 (150)	9-1/2 (240)	10 (250)
capacity - lb (kg)	6 (2.7)	6 (2.7)	22 (10)	55 (25)
type	stationary unit w/ sanitizing circuit	stationary unit w/timed sanitizing circuit	mobile stand, drain, timed sanitizing circuit, corrosion-resistant tank	mobile stand, drain, timed sanitizing circuit, corrosion-resistant tank

• Certified per US & Canada Medical Standards; UL 60601-1 & CSA C22.2 No. 601.1



PARAFFIN THERAPY

Dickson & ParaTherapy Accessories and Refills

Whitehall paraffin refills are of high quality food grade paraffin that provides excellent thermal effects and retention properties. Refills meet FDA requirements and are conveniently packaged in kits of blocks, granules or pouches. Granules and pouches are most suitable for replacing minor solution losses.

A mobile stand option allows for added portability and increased height for upper extremities.

Mobile Stands

PB-221	mobile stand for PB-104
PB-222	mobile stand for PB-101 or PB-107

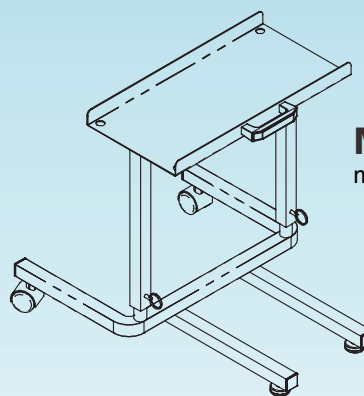

Model PB-222
mobile stand

Refills

RK-36B	refill case of 36 one-pound paraffin granules
PB-301	block kit - 12 one-pound paraffin blocks
PB-320	pouches kit - 6 one-pound easy-open pouches of granulated paraffin



Model RK-36B
Paraffin granules

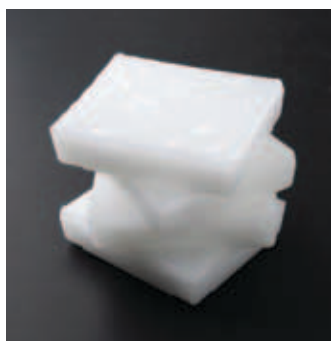

Model PB-301
Paraffin blocks



Model PB-320
Paraffin pouches

