



Whitehall
Manufacturing™

Slant Back Whirlpools

Use



SB Series 100 Gallon Slant Back Mobile Whirlpool

Model SB-100-M



Product photo/image above may show some available options

Whitehall SB-100-M Slant Back Mobile Whirlpool is recommended for treatment of extremities, hip and back area. A slant back design allows for the user to comfortably recline while soaking in the tank.

Tank Capacity is 100 gallons.

Whirlpool Tank is 76"L x 40"W x 24"D and is seamless welded construction, fabricated from heavy gauge, type 304 stainless steel, polished to a satin finish. The tank features a slant back to allow the user to recline while soaking in the tank. A 3" wide rim allows the user to also rest their arms while soaking. Tank bottom is seamless, rounded coved design to minimize bacteria build-up.

Turbine Raising and Lowering Device permits adjustment of desired height and direction of water agitation towards the area of the body to be treated. It is spring balanced and provided with a locking device.

Turbine Assembly functions both as agitator and emptying device. It is equipped with Underwriters Laboratory listed 1/2 HP pump motor protected with an ABS plastic shell, and automatic thermal overload protector, and lifetime-sealed bearings. All parts contacting the water are stainless steel, chrome plated brass or bronze.

Thermometer is provided with a dual scale, adjustable calibration. Stem inserts into a retainer to prevent rattle during whirlpool agitation.

GUIDE SPECIFICATIONS

Provide Whitehall Mobile Whirlpool (specify model number and options) with a 100-gallon capacity, 76"L x 40"W x 24"D. Whirlpool shall be fabricated from heavy gauge, type 304 stainless steel. Construction shall be seamless welded and exposed surfaces shall be polished to satin finish. The tank features a slant back to allow the user to recline while soaking in the tank. The 3" rim allows the user to rest their arms while soaking. Bottom of tank shall be a seamless, rounded coved design to minimize bacteria build-up. Provide a turbine assembly with raising and lowering device which functions both as agitator and emptying device, permits adjustment of desired height, direction of water agitation, and can be locked into place. Turbine assembly shall be UL listed 1/2 HP pump motor with automatic thermal overload protector, and lifetime-sealed bearings. Provide a 3" dial thermometer with a stem retainer to prevent rattle when whirlpool is in operation.

Please visit www.whitehallmfg.com for most current specifications.



Member of
U.S. Green
Building
Council



Recyclable
Product

Whitehall Mfg. > P.O. Box 3527 > City of Industry, CA 91744 > (800) 782-7706 > (626) 968-6681 > FAX (626) 855-4862

SB-100-M

Last Update: 05/06/14



Whitehall Manufacturing™

Slant Back Whirlpools

Series

-SB Slant Back Series

Capacity

-100 Gallons

Type

-M Mobile Whirlpool

Suffix Options (see Whirlpool Option Section for Details)

-ADH Auxiliary Drain Hose Assembly

-ALC Adjustable Low Chair

-ALS Adjustable Low Stool

-EG Enviro Glaze Color Powder Coating

Specify Color: _____

(Special Finish Consult Factory)

MODEL NUMBER AND OPTION SELECTIONS

-GFI Ground Fault Interrupter

-PCS Pump Cover Strainer

-SDP Separate Drain Pump

Turbine rated at 115V, 60Hz; if 220V is required please specify: 50Hz 60Hz

ELECTRIC REQUIREMENTS:
Amps: 8
Volts: 115
Hertz: 60
GFI Receptacle



ALL DIMENSIONS ARE IN INCHES

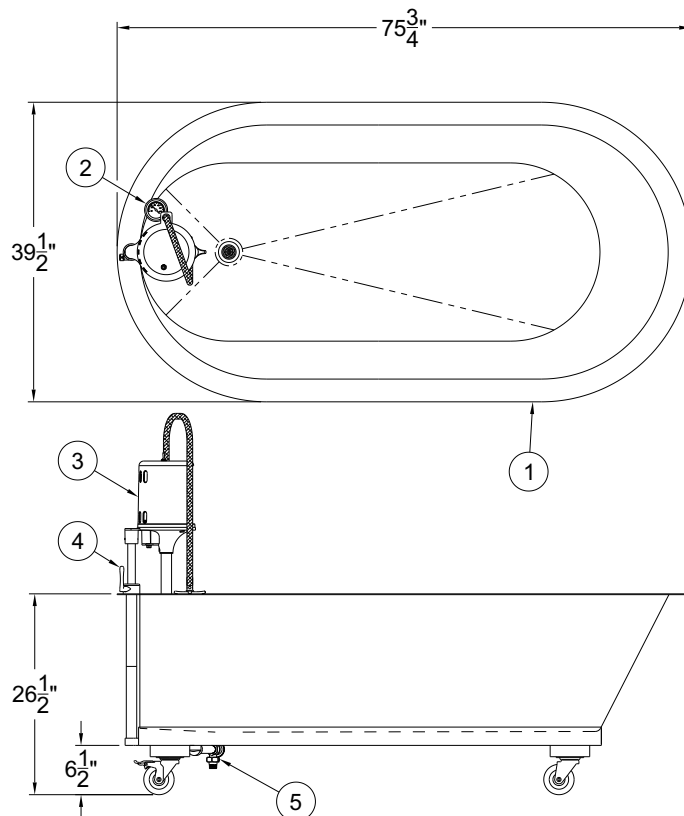

NOTES:

1. SLANT BACK WHIRLPOOL
2. THERMOMETER
3. 1/2" HP PUMP MOTOR
4. TURBINE RAISING & LOWERING DEVICE
5. AUXILIARY DRAIN

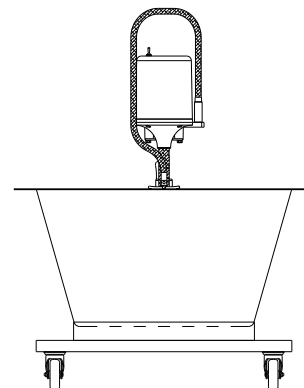

All dimensions are nominal and subject to manufacturer's change without notice. Whitehall assumes no responsibility for use of void or suspended data © Whitehall Manufacturing, Member of Morris Group International. Please visit www.whitehallmfg.com for most current specifications.

SELECTION SUMMARY & APPROVAL FOR MANUFACTURING

Model Number & Options _____ Quantity _____

Company _____ Date _____

Contact _____ Title _____

Approval for Manufacturing/Signature _____

Whitehall Mfg. > P.O. Box 3527 > City of Industry, CA 91744 > (800) 782-7706 > (626) 968-6681 > FAX (626) 855-4862

SB-100-M

Last Update: 05/06/14