

DRY HEAT THERAPY

Thermo-Therapy

Our Thermo-Therapy units feature—

- Even **Temperature Control**
- Heavy-Duty **Construction**
- Overheating **Safety Sensor**

TT-101 & TT-101L
can be used with
-UCH 2-shelf cart



High visibility **digital thermometer**
ensures proper temperature

Adjustable agitation rate for
directed control of fluid-like
whirlpool effect

Adjustable timed operation
for up to 60 minutes of use

Heat range control to
specify temperature



DRY HEAT THERAPY

Thermo-Therapy

The Thermo-Therapy dry heat process offers the same benefits as hydrotherapy without the cleanup. Extremities are inserted into an environment akin to a dry whirlpool, where they are warmly massaged by granulated cellulose called Celstim, which emulates the very pleasant rolling and relaxing effects of water.

Within the chamber, heated air swirls the Celstim around the arm or leg, which retains mobility. Extremities experience a stimulating effect that improves circulation. Thermo-Therapy has also been proven to assist greatly in the desensitization of various scars or other types of nerve pain.



Model TT-101

The **TT-101** model is designed to sit on a table, floor or stand and treat one extremity at a time. The heater is thermostatically-controlled and quickly provides Celstim up to a maximum safety switch-limited 128°F (53.3°C). Treatment time is controlled by a built-in timer, and Celstim temperature is indicated by a digital thermometer. The Celstim capacity is approximately 10 lbs. (4.5 kg) with the heated airstream provided by a single, noise-reduced, variable speed blower.

Model TT-101

10lb unit w/ optional stand



Model TT-101L

12lb unit w/ optional stand

The **TT-101L** is designed for use in a small clinic or office, and is virtually the same as the TT-101, but with a larger chamber and capacity to treat more of the arm or leg. The TT-101L is 3" (76 mm) deeper and 2" (50 mm) longer with a Celstim capacity of approximately 12 lbs. (5.9 kg). The TT-101 and TT-101L can be ordered with an optional stand on casters.

Model **TT-202's** extra large treatment chamber has an approximate 40 lb. (18 kg) Celstim capacity with two top and rear entry ports to treat both arms or both feet at the same time. Two blower motors combine with the heater and are individually controlled through independent speed manipulation to provide varying airflow patterns. This allows for a specific "dry whirlpool" effect to create the most therapeutic dry heat environment.



Model TT-202

40-50lb unit
(front & rear views)

DRY HEAT THERAPY

Thermo-Therapy

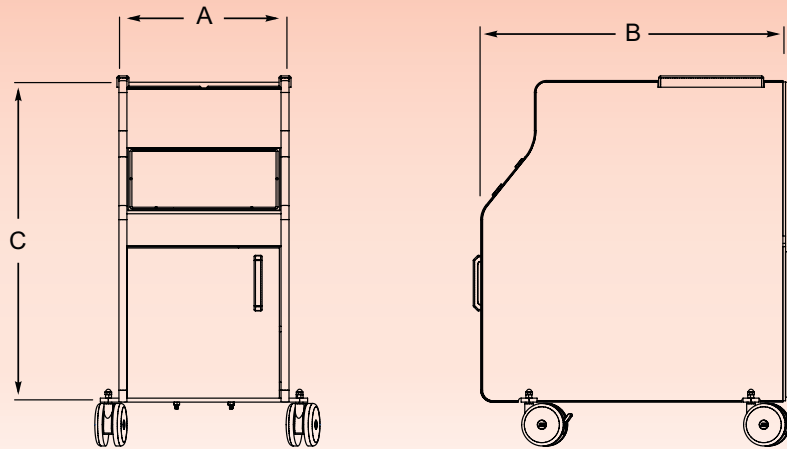

Dry Heat Therapy Units

table top model	TT-101	TT-101L	---
floor model	---	---	TT-202
capacity	10lbs	12lbs	40-50lbs
A - width - in (mm)	19-1/2 (500)	23 (580)	29 (740)
B - length - in (mm)	10-1/2 (270)	10-1/2 (270)	16-1/2 (420)
C - height - in (mm)	15 (380)	18 (460)	35 (890)
usage			

• Certified per US & Canada Medical Standards; UL 60601-1 & CSA C22.2 No. 601.1



Replacement Celstim

TT-908

Two 5-lb (13 kg) plastic containers of sterilized replacement Celstim

Optional Stands

for model TT-101	TT-900	---
for model TT-101L	---	TT-900L
for model TT-101	-UCH	-UCH
width - in (mm)	13-1/2 (340)	13-1/2 (340)
length - in (mm)	30 (760)	33 (840)

For -UCH dimensions, see page 53.