

Location: _____



C1600

DEEP SEAL TRAP WITH FLOOR CLEANOUT

Specification: MIFAB C1600 Series (specify strainer size) deep seal trap cleanout with floor drain strainer, gasketed membrane clamp and side outlet.

Function: Used as a combination floor drain and floor cleanout for access to drainage lines in areas where the floor drain and cleanout are required to be located close together. The membrane clamp is gasketed for a watertight seal and the cover is water and gas tight.

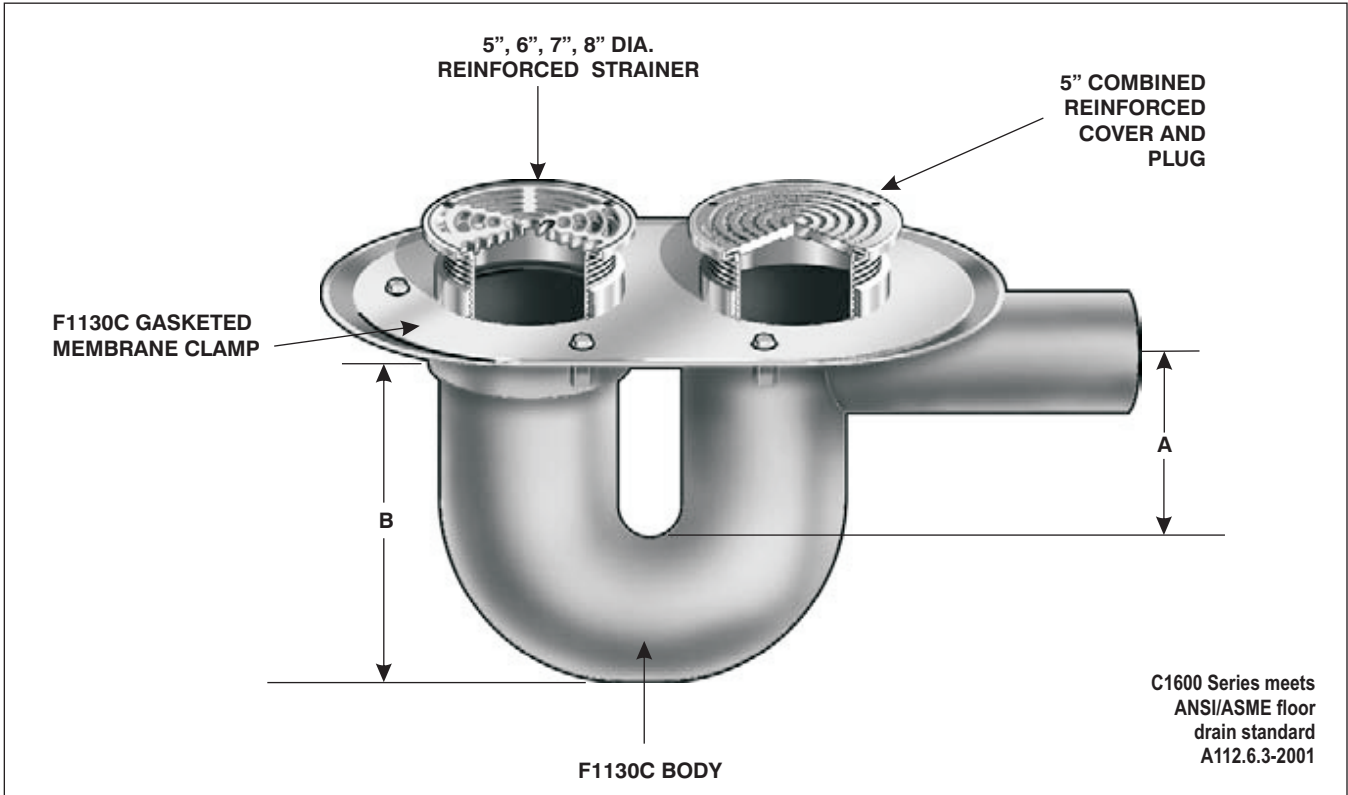

MODEL NUMBER	PIPE SIZE	STRAINER SIZE	STRAINER ADJUSTMENT		ANSI/ASME LOAD RATING STRAINER AND CLEANOUT MATERIAL		
			MIN	MAX	N.B. (-1)	S.S. (-3)	D.I. (-4)
C1602	2" (51)	5" (127)	1 5/8"	2 5/8"	UP TO	5,000	SPECIAL
C1603	3" (76)	6" (152)	1 5/8"	2 5/8"	4,999	TO	DUTY
C1604	4" (102)	7" (178)	1 5/8"	2 5/8"	LBS.	7,499	OVER
		8" (203)	1 7/8"	2 5/8"		LBS.	10,000 LBS.

MODEL NUMBER	PIPE SIZE	A	B
C1602	2" (51) no hub	5 3/8"	13 1/2"
C1603	3" (76) no hub	6"	13 1/2"
C1604	4" (102) no hub	6 1/4"	13 1/2"

SUFFIX	OPTIONAL VARIATIONS:
-1	Nickel bronze strainer and cleanout top
-3	Stainless steel strainer and cleanout top
-4	Ductile iron strainer and cleanout top
-13	All galvanized
-ARRA	ARRA (Stimulus Act) compliant product
-BA	Buy American Act compliant product
-PA	Pennsylvania Steel Act compliant product

Job Name: _____ Page No: _____
 Section No: _____ Contractor: _____
 Schedule No: _____ Purchase Order No: _____