



Use



### E Series 27 Gallon Mobile Whirlpool E-27-M



Product photo/image above may show some available options

**Whitehall E-27-M Mobile Whirlpools** is recommended for treatment of the upper extremities and the lower leg below the knee.

**Tank Capacity** is 27 gallons.

**Whirlpool Tank** is 28"L x 15"W x 21"D and is seamless welded construction, fabricated from heavy gauge, type 304 stainless steel, polished to a satin finish. Tank rim is reinforced with a concealed stainless steel rod. Tank bottom is a seamless, rounded covered design to minimize bacteria buildup.

**Heavy Duty Swivel Casters** support all mobile models. Rear pair of casters are lockable for stabilizing whirlpool during treatment.

**Turbine Raising and Lowering Device** permits adjustment of desired height and direction of water agitation towards the area of the body to be treated. It is spring balanced and provided with a locking device.

**Turbine Assembly** functions both as agitator and emptying device. It is equipped with Underwriters Laboratory listed 1/2 HP jet pump motor protected with an ABS plastic shell, and automatic thermal overload protector, and lifetime-sealed bearings. All parts contacting the water are stainless steel, chrome plated brass or bronze.

**Drain options** auxiliary drain valve on the bottom of the unit. The **E-27-M-SDP** has a bottom drain, leading to a separate, concealed water evacuation pump. A hose is attached to the side of the unit to facilitate the evacuation. The **E-27-M-DS** is constructed with an integral sump which reduces residual water and eliminates the need for a drain.

**Thermometer** is provided with a dual scale, adjustable calibration, and a stem inserts into a retainer to prevent rattle during whirlpool agitation.

#### GUIDE SPECIFICATIONS

Provide Whitehall Mobile Whirlpool (specify model number and options) with a 27-gallon capacity, 28"L x 15"W x 21"D. Whirlpool shall be fabricated from heavy gauge, type 304 stainless steel. Construction shall be seamless welded and exposed surfaces shall be polished to satin finish. Tank shall have a reinforced rim. Bottom of tank shall be a seamless, rounded covered design to minimize bacteria build up. Whirlpool shall have heavy duty swivel casters with locking device on rear pair of casters. Provide a turbine assembly with raising and lowering device which functions both as agitator and emptying device, permits adjustment of desired height, direction of water agitation, and can be locked into place. Turbine assembly shall be UL listed 1/2 HP jet pump motor with automatic thermal overload protector, and lifetime-sealed bearings. Provide a thermometer with a stem retainer to prevent rattle when whirlpool is in operation.



Member of  
U.S. Green  
Building Council



Recycleable  
Product



# Whitehall Manufacturing™

## Extremity Whirlpools

### Series

- -E Extremity Series

### Capacity

- -27 Gallons

### Type

- -DS Mobile Whirlpool with Sump
- -M Mobile Whirlpool
- -SDP Mobile Whirlpool with Separate Drain Pump

### Suffix Options (See Whirlpool Option Section for Details)

- -ADH Auxiliary Drain Hose Assembly
- -AHC1 Adjustable High Chair with Casters
- -AHC2 Adjustable High Chair with Rubber Grips
- -ALC Adjustable Low Chair

- -ALS Adjustable Low Stool
- -ARS Arm Rest Support

### MODEL NUMBER AND OPTION SELECTIONS

- -EG Enviro Glaze Color Powder Coating - Specify Color: \_\_\_\_\_  
(Special Finish Consult Factory)
- -GFI Ground Fault Interrupter
- -PCS Pump Cover Strainer
- -WLS Water Level Sensor

### Turbine Assembly

Electrical on standard turbine supplied is 115 V 60 Hz

if 220 V is required please specify:

- 50 Hz
- 60 Hz

**ELECTRIC REQUIREMENTS:**  
Amps: 8  
Volts: 115  
Hertz: 60  
GFI Receptacle

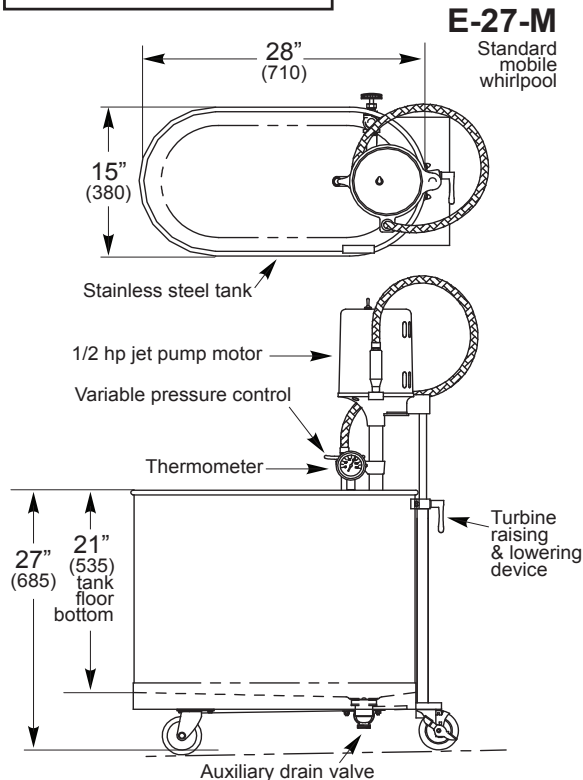

All dimension figures in parentheses are in millimeters.

### E-27-M-SDP

Mobile whirlpool with separate drain pump

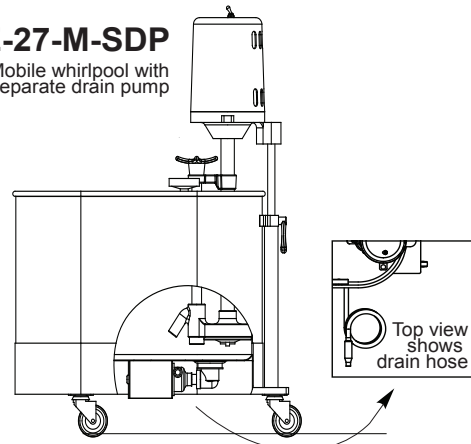

### E-27-M-DS

Mobile whirlpool with sump

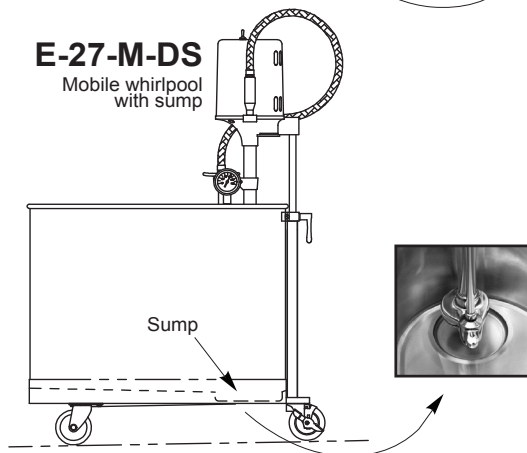

All dimensions are nominal and subject to manufacturer's change without notice. Whitehall assumes no responsibility for use of void or suspended data. © 2008 Whitehall Manufacturing, A Division of Acorn Engineering Company. Please visit [www.whitehallmfg.com](http://www.whitehallmfg.com) for most current specifications.

### SELECTION SUMMARY & APPROVAL FOR MANUFACTURING

Model Number & Options \_\_\_\_\_ Quantity \_\_\_\_\_

Company \_\_\_\_\_ Date \_\_\_\_\_

Contact \_\_\_\_\_ Title \_\_\_\_\_

Approval for Manufacturing/Signature \_\_\_\_\_

Whitehall Mfg. > P.O. Box 3527 > City of Industry, CA 91744 > (800) 782-7706 > (626) 968-6681 > FAX (626) 855-4862