

Location: _____



R1260

**EXTRA LARGE SUMP
HIGH FLOW ROOF DRAIN**

Specification: MIFAB® Series R1260 lacquered cast iron extra deep sump roof drain with 16 5/8" diameter anchor flange, cast iron waterproofing membrane clamp ring with integral gravel stop, and standard self-locking polyethylene dome strainer with a free area of 125 square inches.

Function: Used in any type of flat roofs. Extra deep sump and large free area dome provides for efficient drainage of rain water and prevents debris from entering the drain line. Extra wide anchor flange and membrane clamp with tongue in groove design provides for secure grip of membrane and roof flashing materials.

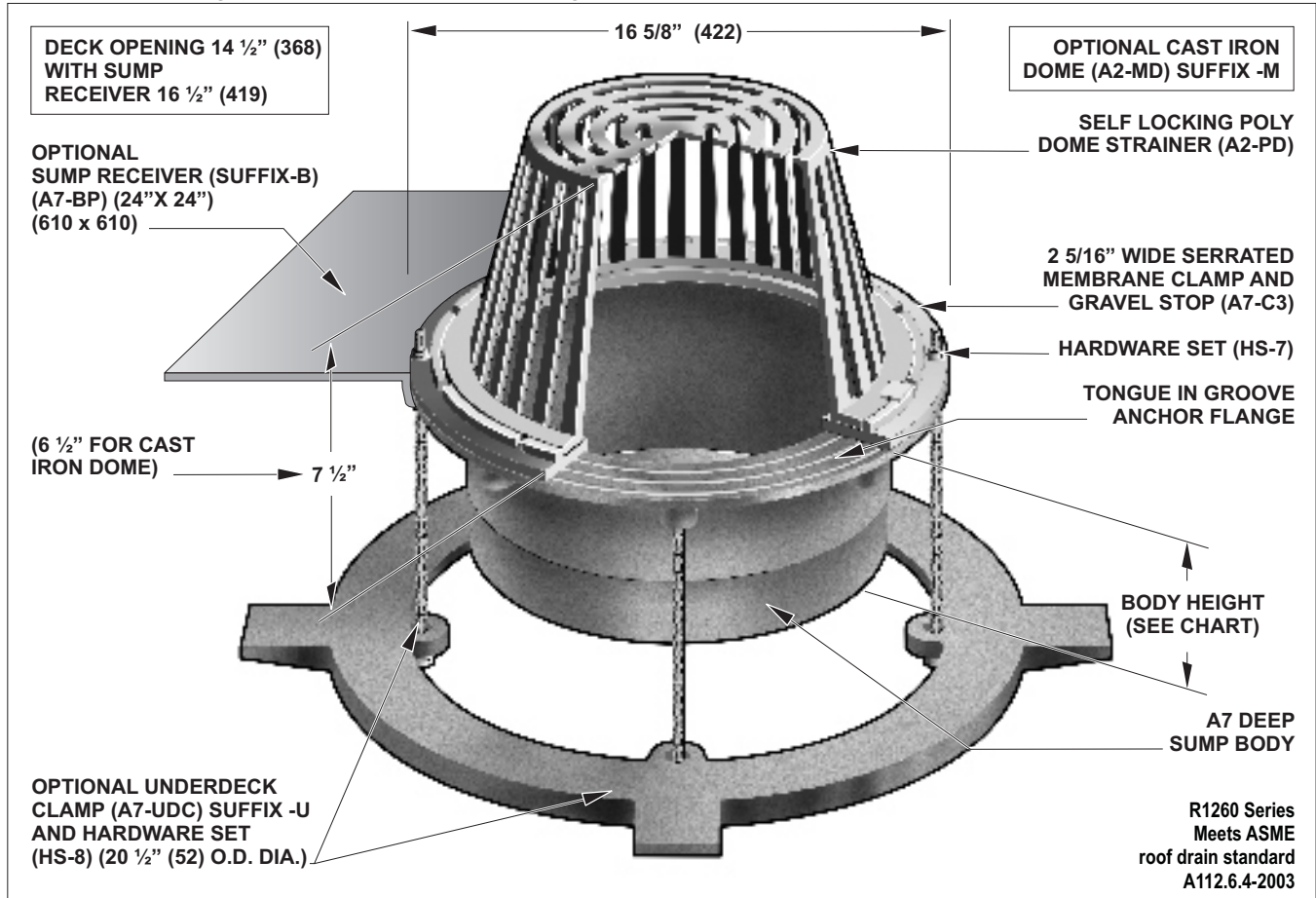

PIPE SIZE	BODY HEIGHT	
	NO HUB (STANDARD)	INSIDE CAULK (X)
10" (254)	5 1/2" (140)	10" (254)
12" (305)	5 1/2" (140)	—

- SUFFIX**
- 6 Vandal proof dome (metal dome only)
 - 11 Acid resistant epoxy coating
 - 12 Galvanized metal dome
 - 12A Galvanized body and membrane clamp
 - 12B Galvanized metal dome and membrane clamp
 - 13 Galvanized body, membrane clamp and dome
 - 81 Rough bronze dome
 - 83 Stainless steel mesh screen over dome
 - (Standard) No hub outlet
 - ARRA ARRA (Stimulus Act) compliant product
 - B Sump receiver
 - BA Buy American Act compliant product
 - C Secondary clamp
 - E Adjustable extension
 - EG Galvanized adjustable extension

- SUFFIX**
- G Stainless steel ballast guard
 - JC S.S. Ballast guard with secondary clamp
 - M Cast iron dome
 - M-80 Low profile aluminum dome
 - PA Pennsylvania Steel Act compliant product
 - R 2" external water dam
 - U Underdeck clamp
 - U3 Underdeck clamp with cutaway side
 - V Fixed Static Extension (2", 3", 4")
 - W Adjustable water dam (4" dia.)
 - W-1 Water proofing flange
 - W2 2" internal water dam
 - W3 3" internal water dam
 - W4 4" internal water dam
 - W6 6" diameter adjustable water dam
 - X Inside caulk outlet (10" only)
 - Z Extended wide elastomeric flange

Job Name: _____ Page No: _____
 Section No: _____ Contractor: _____
 Schedule No: _____ Purchase Order No: _____